

GMR HD 16 A

POTAIN ®

Courbes de charges - Lastkurven - Load diagrams - Curvas de cargas - Curve di carico



2000kg

2,6 →	9,8	11	12,2
22 m	2000	1715	1500
2,4 →	9,8	11	12,2
20 m	2000	1715	1500

2000kg

8,8	9	10	11	12	13	14	15	16	17	18	19	20	21	22	m
2000	1935	1685	1485	1325	1195	1085	990	915	845	785	730	680	640	600	kg
	9,4	10	11	12	13	14	15	16	17	18	19	20			m
	2000	1835	1620	1450	1305	1190	1090	1000	925	860	800	750			kg

1500kg

2,6 →	12,2
22 m	1500
2,6 →	12,2
20 m	1500

1500kg

10,9	11	12	13	14	15	16	17	18	19	20	21	22	m
1500	1485	1325	1195	1085	990	915	845	785	730	680	640	600	kg
	11,7	12	13	14	15	16	17	18	19	20			m
	1500	1450	1305	1190	1090	1000	925	860	800	750			kg

Flèche relevée - Ausleger in Steilstellung - Luffing jib - Flecha izada - Braccio impennato

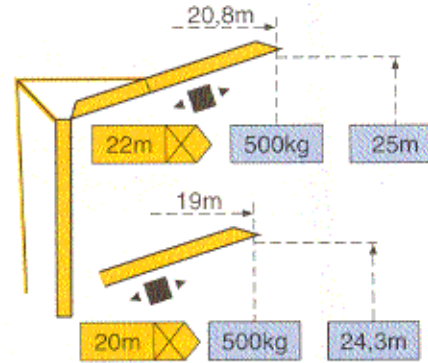
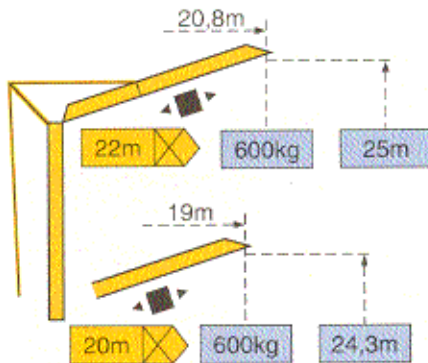

◀ ■ ▶ Chariot distributeur Verfahrbare laufkatze Traversing trolley Carro distribuidor Carrellino distributore

Réaction - Eckdrücke - Reactions - Reacciones - Reazioni

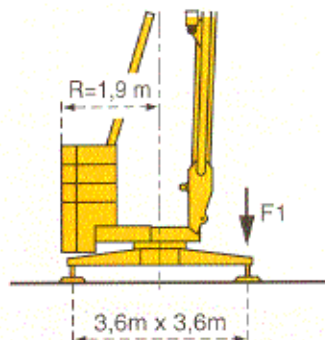

F1	● 11,7t	■ 8,6t
⊕	7t	

● En service
■ Hors service

● In Betrieb
■ Ausser Betrieb

● In service
■ Out of service

● En servicio
■ Fuera de servicio

● In servizio
■ Fuori servizio

⊕ A vide sans lest ni train de transport avec flèche et hauteur maximum.

⊕ Ohne Last, Ballast und Transportachse, mit Maximalausleger und Maximalhöhe.

⊕ Without load, ballast or transport axles, with maximum jib and maximum height.

⊕ Sin carga, sin lastre, ni tren de transporte, flecha y altura máximas.

⊕ A vuoto, senza zavorra ne assali di trasporto con braccio massimo e altezza massima.

Mécanismes - Antriebe - Mechanisms - Mecanismos - Meccanismi

				m/min	kg	ch -PS hp	kW
Levage Heben Hoisting Elevación Sollevamento	2000kg	9 PC 10		6,6	2000	8,2	6
				20	2000		
				40	1000		
		6 PC 7		9,5	1500	6	4,4
				19	1500		
				38	750		
	6L 2V 7		19	1500	6	4,4	
			38	750			
	Distribution - <i>Katzfahren</i> - Trolleying Distribución - Distribuzione		2 D2 V4	18 - 36	2000	2	1,5
			2 DC1 V2	30	1500	2	1,5
	Orientation - <i>Schwenken</i> - Slewing Orientación - Rotazione		RCO 10	0 → 0,3 - 1 tr/min - U/min - rpm		1,5	1,1
	Réseau - <i>Netzstrom</i> - Mains supply - Red - Rete elettrica						380V.50Hz
Puissance électrique nécessaire - <i>Anschlusswert</i> - Necessary electric power Potencia eléctrica necesaria - Potenza elettrica necessaria						9PC:12 kVA 6PC - 6L2V: 10kVA	
Groupe électrogène - <i>Stromaggregat</i> - Generator set - <i>Grupo electrogeno</i> - Gruppo elettrogeno						•	

*Nous consulter - *Auf Anfrage* - Consult us - *Consultarnos* - Consultateci

Conforme à la directive CEE 84/534 sur le niveau acoustique - *Gemäss EWG-Richtlinie 84/534 Schall- Leistungspegel*

In compliance with the EEC 84/534 Instruction on noise level - *Conforme con la direttiva CEE 84/534 sobre el nivel acustico*

Conforme colla direttiva CEE 84/534 sul livello acustico

Montage - Montage - Erection - Montaje - Montaggio

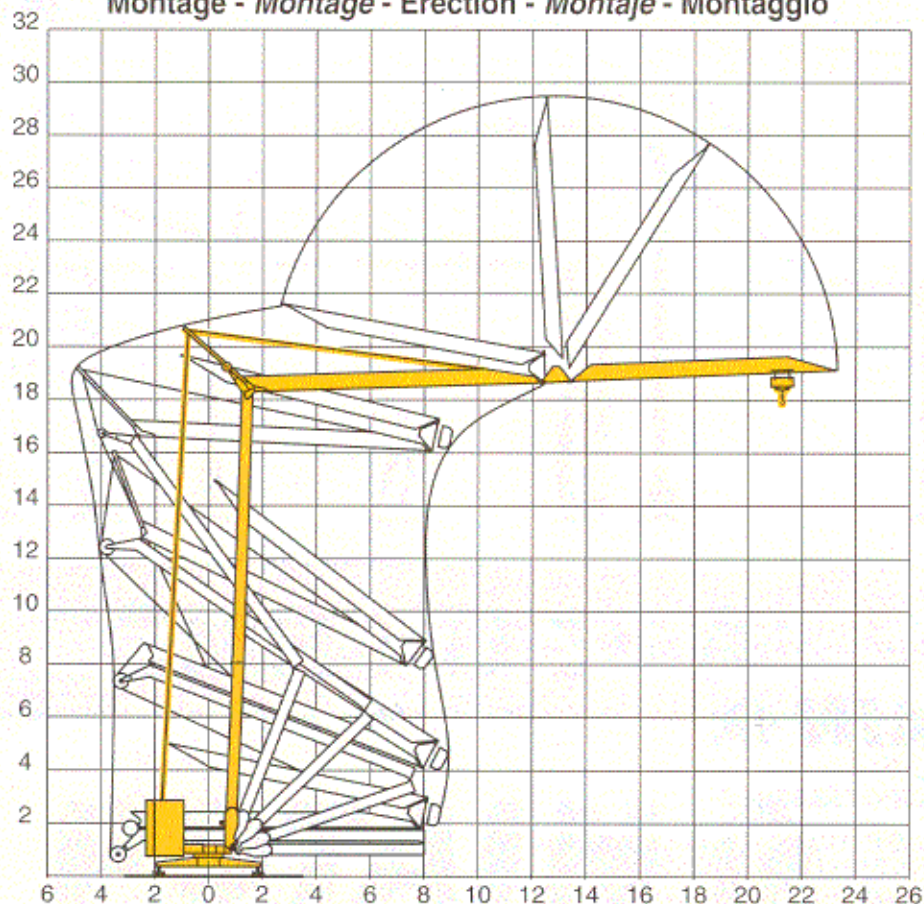

Transport - Transport - Transport - Transporte - Trasporto

18/27
15A/25A
14A/21A

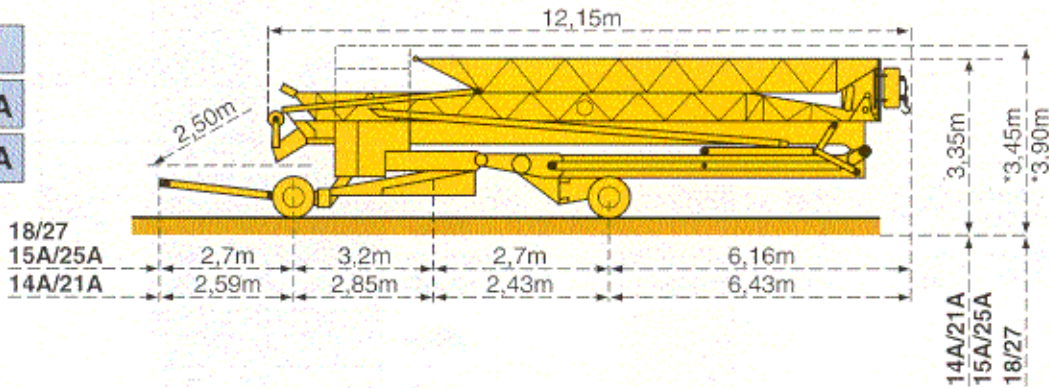

DJ125/S105
DS60/S105
DS60/S80
DS51/S70

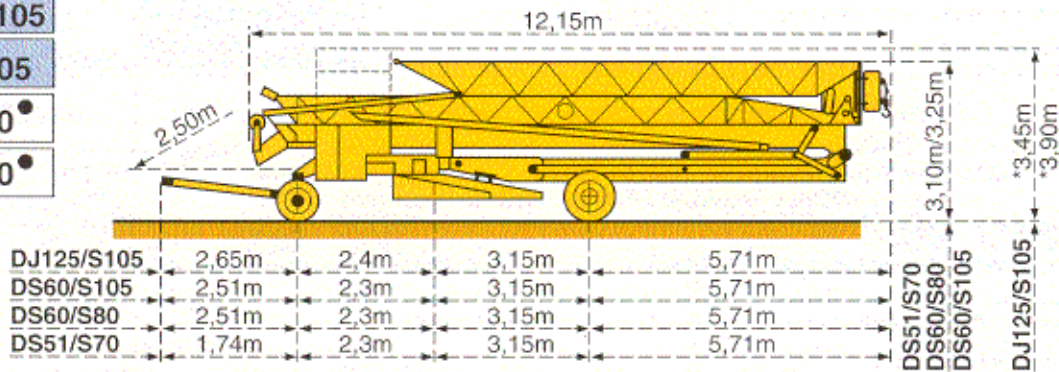

● Chantier
Baustelle
Site
Obra
Cantiere

*Selon pays - Je nach Einsatzland - According to country - Segun pais - Secondo i paese



NF E 52081 - 82
DIN 15018.H1 B3

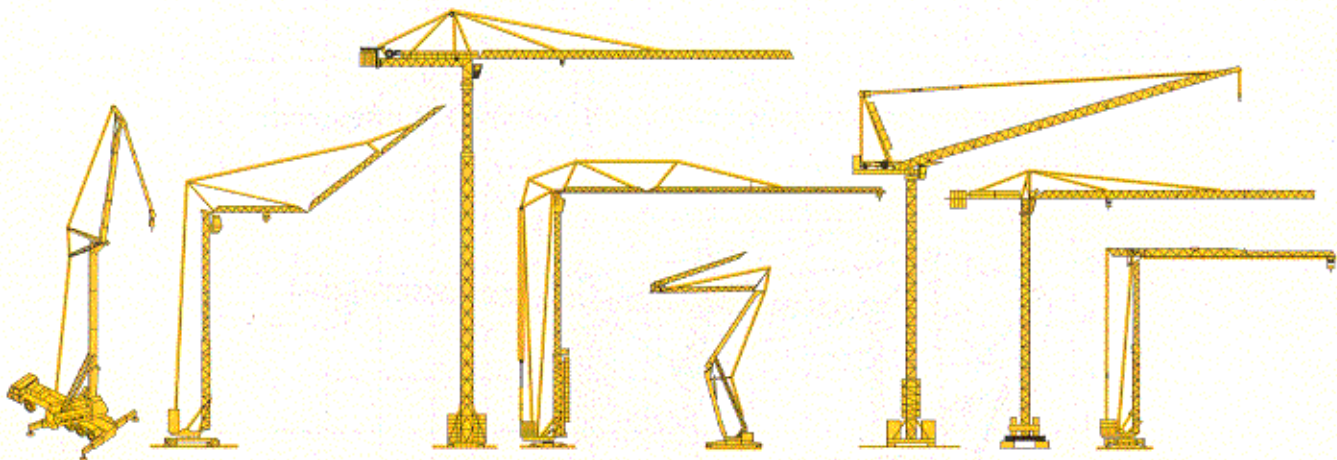

Document pour usage commercial uniquement - Benutzung dieser Unterlagen nur für Verkaufszwecke - Document for commercial use only -
Documento para uso comercial unicamente - Documento per uso commerciale solamente

Copyright.Reproduction interdite © POTAIN 1992

POTAIN ↑

GRUPE LEGRIS INDUSTRIES

18.Rue de Charbonnières, B.P. 173-F 69132 ECULLY Cedex
Tél. 72.20.20.20 - Télex 375 213 - Fax 72.20.20.00
POTAIN GmbH Deutschland Tel: 06.105.704.0
POTAIN U.K. Great Britain Tel: 0895.44.52.61
Simma POTAIN Italia Tel: 02.97.96.71
POTAIN Portugal Portugal Tel: 02.968.08.89

GMR HD 16 A

Réf. 1992 - 38 - LFJ 4



SERVICE



VERMIETUNG



VERKAUF



Bau- und Industriekrane
Schwertransporte
Hydraulikservice
LKW-Kranarbeit
Arbeitsbühnen
Teleskoplader



Wahlenstrasse 175, 4242 Laufen



061 781 55 11



info@bischag.ch

